

CONTROL OF MICRO-INVERTERS AS AN OVERVOLTAGE PREVENTION METHOD UNDER HIGH PV PENETRATION

SUMMARY

Low voltage (LV) residential grids are generally not designed for high penetration of photovoltaic (PV) distributed generation. Maximization of PV output is not only opposed by solar energy intermittency, but also by grid impacts in form of reverse power flow and overvoltage. More intelligent control of PV inverters is required to balance the voltage requirements of the grid and maximum energy yield wanted by the end user. This paper discusses how micro-inverter topology could be utilized to handle overvoltage problem and avoid power output losses by applying an innovative control method. Control is realized as partial generation shedding at PV module level which is an optimized alternative comparing to conventional, entire PV array tripping in the event of overvoltage.

Keywords: voltage control, micro-inverter, photovoltaic, power quality, distributed generation

STRESZCZENIE

Niskonapięciowe systemy paneli słonecznych do użytku domowego mają istotne ograniczenia dotyczące intensywności zachodzących w nich zjawisk fotowoltaicznych. Ujemny wpływ na maksymalną efektywność tego typu układów mają nie tylko okresowe przerwy w nasłonecznieniu, lecz również przepięcia występujące w tych układach. Skuteczne sterowanie pracą przelazników napięcia jest bardzo istotne dla zapewnienia wymaganego napięcia oraz maksymalizacji mocy dostarczanej do końcowego użytkownika. W pracy zaprezentowano koncepcję wykorzystania topologii mikroprzelazników oraz nowatorską metodę ich sterowania, umożliwiającą rozwiązywanie problemów związanych z przepięciami oraz zmniejszenia strat mocy wyjściowej. Sterowanie jest realizowane na poziomie poszczególnych modułów fotowoltaicznych.

Słowa kluczowe: regulator ładowania, generacja rozproszona, zjawiska fotowoltaiczne, jakość energii elektrycznej

1. INTRODUCTION

Ambitious international goals to increase the electricity generation from renewable energy sources are pushing building standards towards integrating renewables into so called net zero energy buildings (NZEB). Communities, driven by high electricity bills and attractive government incentives for installing renewable energy generators, are equipping buildings with grid-tied photovoltaics (PV). Such trends are heading towards neighborhoods with nearly 100% PV penetration (generation to demand ratio). PV systems face a number of challenges when trying to maximize their power output and deliver the electricity to the point of use. Panel mismatch problem that drives down the system efficiency is more pronounced in residential and commercial distributed PV than in dedicated plants due to partial shading effects, soiling, roof obstacles, etc. Another problem is inability of grid infrastructure to host large distributed generation (DG) without negative impacts such as overvoltage. Finally, the problem of overvoltage is unequally distributed along the LV feeder which leads to the unfair sharing of power losses among PV system owners. There is increasing interest from the research community to actively involve PV generators in power quality improvement by adding more control to the

inverter (Demirok et al. 2010, Tonkoski and Lopes 2011) or by adding storage to absorb the excess power (Paatero and Lund 2007, Ueda et al. 2008). The challenge of such modification is added cost to the PV system as it might require modification of electronics and a dedicated communication channel that will coordinate multiple PV systems.

2. THE OVERVOLTAGE PROBLEM

In residential grids PV generation is known to be badly correlated to the household load profiles. During noon hours low load is mismatched against PV production peaks. Most critical cases for this mismatch represent summer months in high latitude areas (Widén et al. 2009). Technical surveys done in USA, Japan and several developed EU countries show successful large scale integration of PV communities. Installed capacities range 0.9–6 kWp/house and 4.8–34 kWp/building (IEA-PVPS 2008). It should be kept in mind that these surveys are in developed countries with good grid infrastructure and in urban areas. But even so, in some PV communities in Japan with 2.6–5 kWp/household, utilities did have to intervene with capital investments like reinforcing distribution lines and adding more transformers. In another case in Japan, 553 PV sys-

* AGH University of Science and Technology, Faculty of Mechanical Engineering and Robotics, Department of Robotics and Mechatronics, Krakow, Poland, gagrica@agh.edu.pl; tuhl@agh.edu.pl

** Technische Universiteit Eindhoven, Department of Electrical Engineering, Eindhoven, Netherlands

Table 1

Power flow simulations in LV networks under high PV penetration scenarios

Country	LV Network type	PV capacity experiencing overvoltage [kWp/household]	Overtoltage level / limit set by utility (per unit [p.u.])	PV penetration level
Finland (Paatero and Lund 2007b)	Urban *	2	1.055 / 1.025	200%
United Kingdom (Thomson and Infield 2007)	Urban	2.16	1.028 / 1.02	50%
Canada (Tonkoski et al. 2012)	Suburban	2.5	1.068 / 1.042	75%
Sweden (Widén et al. 2010)	Urban	5	>1.05*	100%
Sweden (Walla et al. 2012)	Rural / Urban	not stated	>1.1*	60% / 325%

* small finite probability of voltage crossing above utility levels

tems (3–5 kWp/system) had to install batteries for matching the excess power (Ueda et al. 2008). Several utilities in developed EU countries (PVUPSCALE WP4, 2007) were surveyed and they experience no overvoltage problem in communities where PV was introduced at a high level, but nearly all of them are expressing concerns for voltage rise in the future when PV penetration increases. Concern is expressed specifically for weak and rural grids with higher voltage variations.

Table 1 shows simulations that were done for single house buildings in urban and rural LV grids settings to determine the level of installed capacities per single house at which overvoltage occurs. It can be seen that not every grid in every country starts from the same position when facing the integration of PV. Swedish city grid can handle extreme 325% PV penetration due to the grid planning for heavy heating loads.

3. BENEFITS OF MICRO-INVERTER TOPOLOGY

Most inverters installed in the world today meet basic protection like disconnecting when voltage exceeds limits, then reconnecting after voltage has normalized (on/off method

better known as ‘inverter tripping’). This is the most preferred method for utilities to solve overvoltage coming from DG and, in most cases, the only legal option for PV system owner. When inverter trips, AC power output is zero and the reconnection timer is activated. Inverter stays offline usually for 5 min and then tries to reconnect provided that voltage is within normal operating range (Dargatz 2010, SMA 2010). In grids saturated with PV penetration it can be expected that overvoltage occurrences increase which can create large production losses. This adds up to the system losses such as partial shading, soiling etc. Under increased losses the technological choice should be directed at solutions that provide increased energy harvesting. Per panel electronics in form of DC/DC converters (energy optimizers) and DC/AC inverter (micro-inverters) is a fast growing market due to highly efficient realization of maximum power point tracking (MPPT) with capability of increasing the energy harvest up to 25% (Lee and Raichle 2011). With energy optimizer installed, panels are still connected in a string with one inverter presenting single point of failure (disconnect), but micro-inverters independently connect each panel to the grid (fig. 1). There are several benefits of such topology: per panel

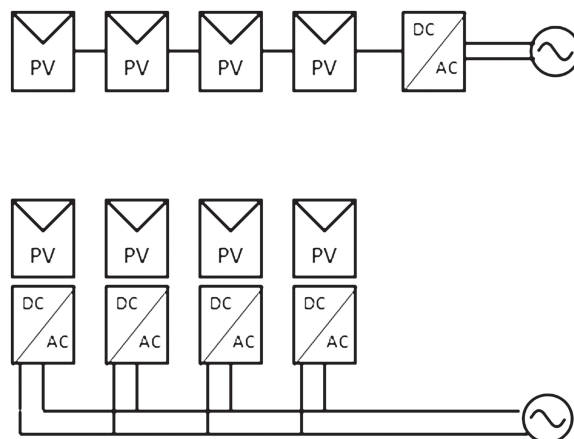

Fig. 1. Inverter topologies: string inverter (top), micro-inverters (bottom)

monitoring and easier problem spotting; multiple points of failure (one faulty inverter will not affect other inverters in the array); less complex installation due to AC wiring; increased safety due to DC voltage not bigger than 60 V; 25 year warranty that follows the life time of the panel while string inverter warranty doesn't go beyond 15 years.

The micro-inverter benefits mentioned so far are mostly of interest to the system owner, but the very same topology creates many opportunities for smart grid applications that should be of interest to utilities too. One of such would be control method for PV output guided by overvoltage prevention.

4. CONTROL METHOD DESCRIPTION

From figure 1 it can be said that each panel is a micro PV plant comparing to a single, monolithic array. Also each AC relay inside the micro-inverter is controlled independently. In present commercial use, when overvoltage threshold set by utility is reached, all micro-inverters shutdown. Control

system proposed in this paper assumes that part of array can be shed for voltage control while the rest can remain in production. The operational limit is determined by start voltage (V_{START}) and stop voltage (V_{STOP}) at the point of common coupling (PCC). V_{START} goes slightly below the utility threshold and V_{STOP} depends on utility decision. Some utilities have more strict voltage requirements while others can allow working under certain increases and allowing more green energy to be fed into the grid. Control algorithm is shown in figure 2. When execution is triggered, micro-inverters are switched off in cascades until V_{STOP} is reached. Cascaded generation shedding is achieved by implementing a progressive time delay to the 'OFF' signal going towards each micro-inverter. This delay gives the voltage sampling block enough time to sample the new voltage value before the next micro-inverter is shutdown. If the value meets the V_{STOP} the cascaded shedding sequence is stopped by sample & hold. Once voltage is within limits, grid reconnection is restored by initialization procedure that already exists in each micro-inverter, therefore no dedicated 'ON' signal is necessary at supervisory control level.

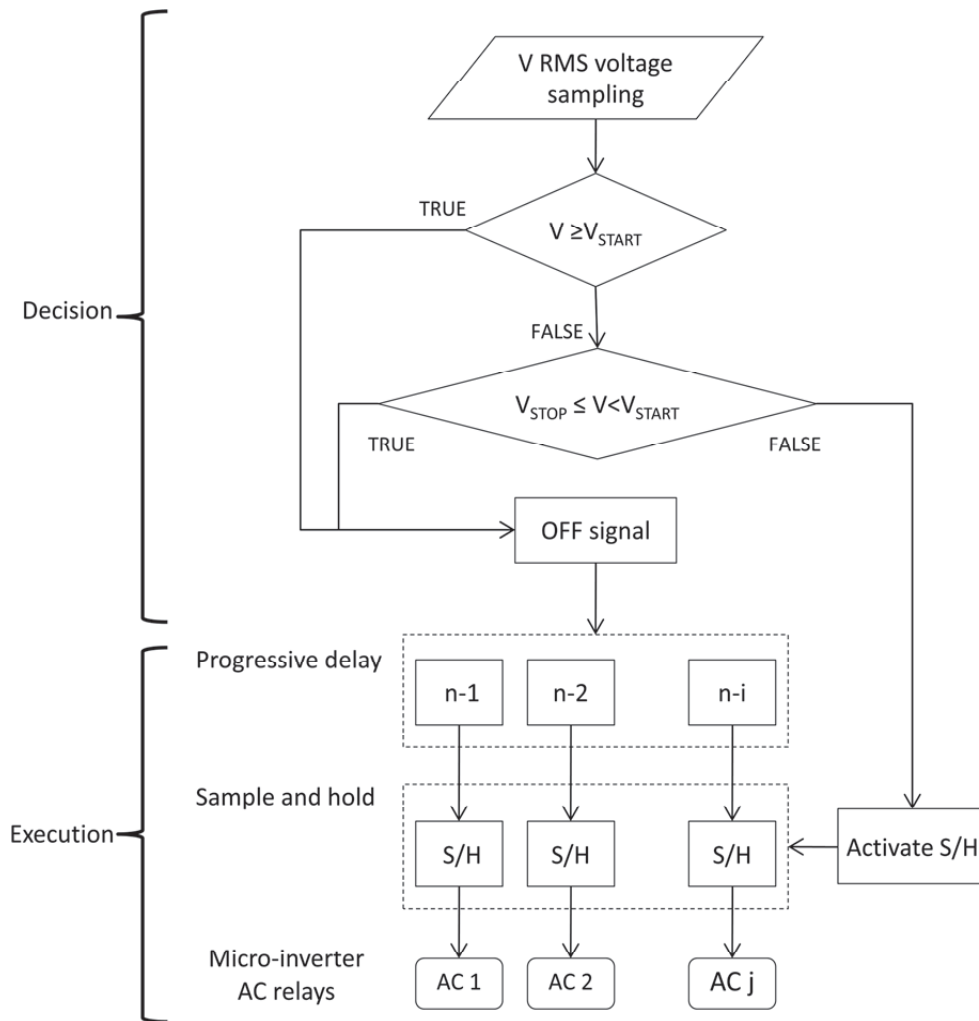

Fig. 2. Supervisory control algorithm for a group of micro-inverters

It should be noted that implementation of supervisory control can be done in a very economic manner. Commercially available micro-inverters already come with a remote monitoring system capable of updating micro-inverter firmware, changing some control parameters, etc. Based on (Attanasio 2012) it is known that AC relay that responds to signals from embedded micro-controller can also respond to signal made by external application by simple firmware change. Therefore there is no added cost associated with hardware changes to micro-inverter logic.

5. MODEL DESCRIPTION

Model is set as a worst case scenario with constant high generation and constant low load. Worst case method is known to be used by distribution operators for determining the DG maximum allowed to connect to LV grid (Viawan 2006). Two models were created: single house model and LV grid model. Single house model was used for developing and tweaking the control on constant equivalent impedance at PCC. Once desired response to control was achieved the model was placed as subsystem in LV grid model in order to study the ef-

fects of control system under varying equivalent impedance due to changing load and generation in the circuit.

5.1. Single house model

Model consists of 8 micro-inverters, load, and PCC impedance. Nominal PV power is 2.8 kWp. Micro-inverters are modeled as 350 W AC current sources with 660 nF capacitance in parallel to represent EMI filter (Enphase 2013, personal communication). This is a reduction of a two stage micro-inverter model (fig. 3).

House load is set to 500 W based on empirical residential demand data at 12:00 pm, collected in (Widén et al. 2010, Bennich and Persson 2006). Reactive energy is not considered in this paper as it can assist the DG in coping with overvoltage which is completely different method of voltage control. Therefore load operates at unity power factor. Equivalent impedance at PCC is modeled as purely resistive. It is set to cause overvoltage of 255 V which is beyond the 1.1 p.u. limit recommended by EN 50160 standard. Simulink model for single house together with supervisory controller is presented in figure 4.

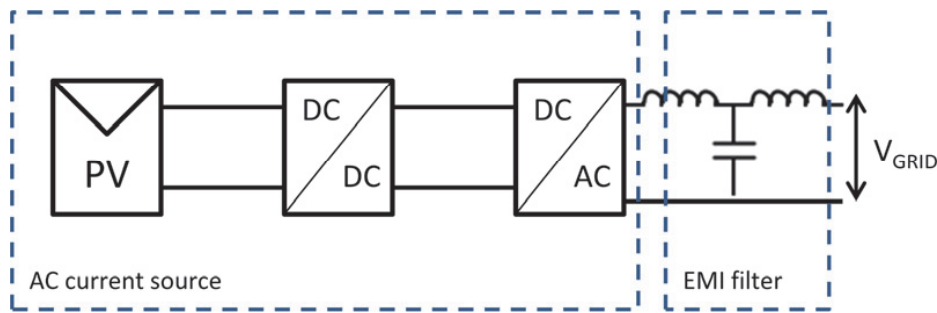

Fig. 3. Two stage micro-inverter model reduction

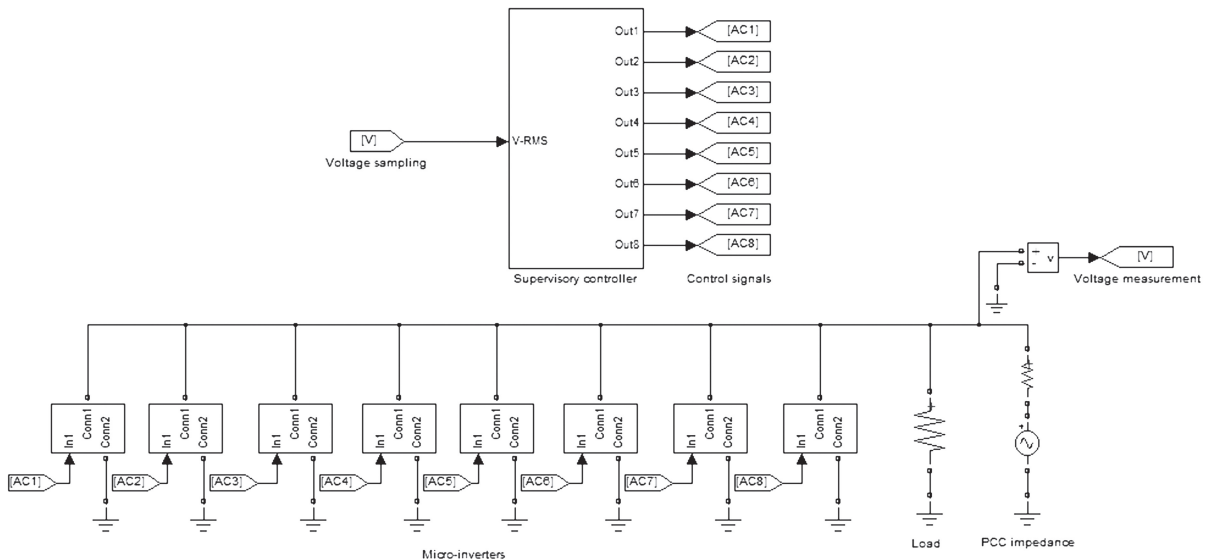

Fig. 4. Simulink model of a single house micro-inverter system with voltage control

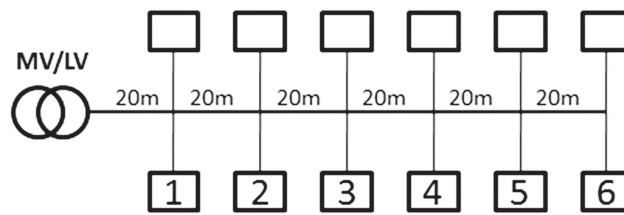

Fig. 5. Residential LV node

5.2. LV grid model

Suburban grid model was made according to (Tonkoski and Lopes 2011). It consists of 12 single house models connected to the 14.4 kV/240 V single phase transformer with 75 kVA capacity. Transformer primary is connected to an ideal AC voltage source (14.4 kV, 50 Hz) therefore effects on the medium voltage grid are out of scope of this paper. Every two houses are connected at the same point on the feeder, thus forming 6 house pairs with distance of 20 m from each other. House numeration is from 1 to 6, where House 1 is the closest and House 6 is farthest from transformer (fig. 5). Total feeder length is 120 m. Feeder is modeled as a single phase PI section with the following RLC characteristic: $R = 0.346 \Omega/\text{km}$, $L = 0.24 \text{ mH}/\text{km}$, $C = 0.072 \mu\text{F}/\text{km}$. For simplicity drop lines for service connection were not modeled. All houses having 2800 W generation and 500 W demand creates an extreme net positive neighborhood (560% PV penetration) which is highly unlikely to occur in reality, but it is useful for observing control response in critical conditions.

6. SIMULATION RESULTS

Simulation was done using Matlab/Simulink software. Simulation time was set to 5 min considering that this is the standard inverter disconnection duration. Simulation results

are presented first for the single house model then for the LV grid model.

6.1. Single house simulation results

Control system setup is given in table 2 and the effect of control algorithm on voltage levels is shown in figure 6.

Table 2

Controller setup for the single house model

Control parameter	Value
V_{START}	1.06 p.u.
V_{STOP}	1.04 p.u.
Switching signal delay setup	0.5 s – 4s with 0.5 s increase for each micro-inverter
Voltage sampling	2 s

Simulation starts with overvoltage of 255.5 V. This over 10% of normal voltage meaning the system must respond within 1 second (Dargatz 2010, SMA 2010). Voltage response in a) happens for 2 s voltage sample rate. Five steps of voltage drop are caused by cascaded shedding of 5 micro-inverters. Close to 235 V shutdown sequence stops and 3 micro-invert-

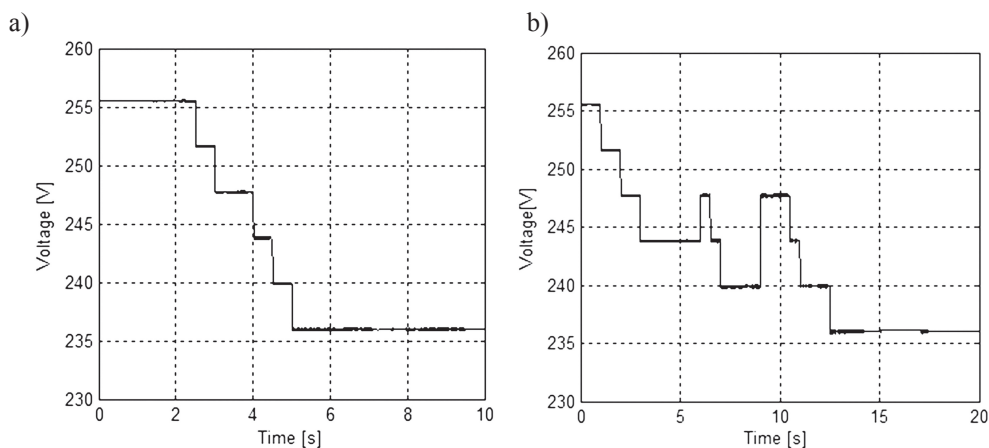

Fig. 6. RMS voltage response to micro-inverter control. Effects of different voltage sampling on voltage response are shown: a) 2 s sample rate and b) 1 s sample rate

ers are left in operation. In conventional overvoltage protection all micro-inverters would be shut down and produce 100% system loss. Proposed control was able to avoid loss for 33.7%. V_{STOP} is reached after 5 s, but initial response should be quicker. In b) attempt was made to fix the response time by changing the sample rate to 1 s. While 1 s response was achieved, there is a premature power up of micro-inverters between 5 s and 10 s, and V_{STOP} is reached after 12 s.

6.2. LV grid simulation results

Controller setup is the same as in table 2 with the exception of V_{START} being lowered to 1.05 p.u. Reason for change is that at 1.06 p.u. first 2 houses did not experience overvoltage

and the idea was to test under more strict condition. Even though the model contains 12 houses there are no difference in simulation results for houses that share the same PCC (i.e. house pair). Figure 7 shows voltage profile for House 1 and House 2 during 5 min simulation. Because control is now distributed and executed at multiple points in the grid, voltage step ups/downs seen at one house cannot be attributed only to control system of that particular house (as in fig. 6), but to neighboring houses as well. House 1 does not experience overvoltage, but equally contributes to the overvoltage problem as other houses. However, control actions in other houses also lower the voltage of House 1. This shows that proposed control system, when distributed in LV grid, can have wider impact than just local voltage regulation.

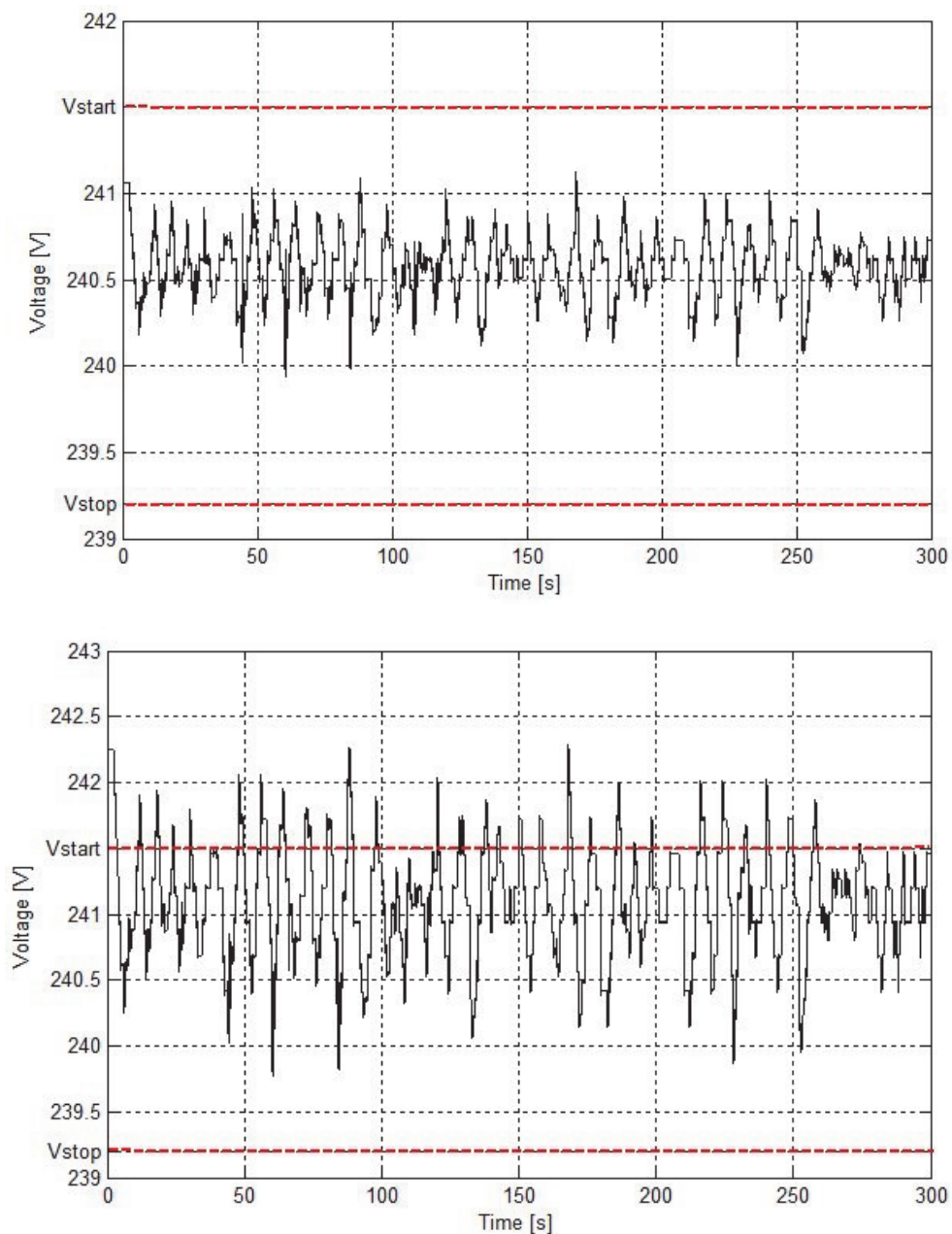

Fig. 7. RMS voltage profile of House 1 (top) and House 2 (bottom) in the LV feeder

At the House 2 it can be seen that, although capable of reducing initial overvoltage (242.3 V), there are 28 occurrences when voltage was over 1.05 p.u. If the requirement was less strict (i.e. 1.1 p.u.) House 2 voltage profile would be acceptable from voltage requirements point of view. Cascaded on/off sequences are not coordinated between different PV systems and in some instances they happen simultaneously in different locations causing high magnitudes. Reasons for system not keeping well between V_{START} and V_{STOP} is that control algorithm was not well optimized in simulink. Table 3 shows generated energy for each house during the overvoltage event. Conventional voltage trip triggered in houses 2–6 would cause 100% loss during 5 min time, but proposed control is able to avoid losses (91.4% at House 2 and around 57% in the remaining houses. On the whole grid level avoidance of loss is 68.7%.

Result in table 3 also confirm a problem that is repetitive in similar studies (Ueda et al. 2008, Tonkoski and Lopes 2011, Demirok et al. 2010) and concerns the unfair distribution of output losses along the feeder. Overvoltage along the feeder increases as DG is placed further away from the transformer. This causes control action to be triggered more often than in houses that are closer to transformer. In this study all systems contribute to the problem equally, but House 1 didn't even experience overvoltage. Despite the increase in voltage along the feeder, it seems that proposed control has a tendency to equalize losses among affected PV without using dedicated channel for coordination. It needs to be repeated that such positive result is achieved at the expense of unoptimized control system, which has a consequence of cascaded shut-down/ power-up cycles happening too often. Such fast cycling puts a great stress on systems in houses 2–6 due to fast switching of micro-inverter AC relays. In reality AC relays cannot operate like that and their lifetime would be greatly

impacted. The effects on the transformer were not thoroughly investigated in this paper except for the measured capacity. During simulation the transformer load peaks did not cross 24.5 kVA and maximum capacity is 75 kVA (fig. 8).

Table 3

Energy generated at each house during 5 min overvoltage event. If there was no voltage limitation each house would generate about 0.229 kWh in 5 min time

House	Starting voltage [V]	Generated power [kwh]	Loss avoidance [%]
1	241.1	0.2087	100*
2	242.3	0.2094	91.4
3	243.2	0.1311	57.2
4	243.9	0.1313	57.3
5	244.4	0.1315	57.4
6	244.6	0.1315	57.4

* Only in the sense of local control not being triggered. But due to the impact on voltage from neighboring control systems there is actually a loss gain of 8.9%

7. CONCLUSION

This paper proposed a cascaded generation shedding of a PV array utilizing the micro-inverter topology with the purpose of voltage control and output loss prevention in comparison to conventional inverter tripping. Simulation results show that it is possible to assign only part of array to solve overvoltage problem while the rest of the array remains in production and therefore avoid entire array trip-

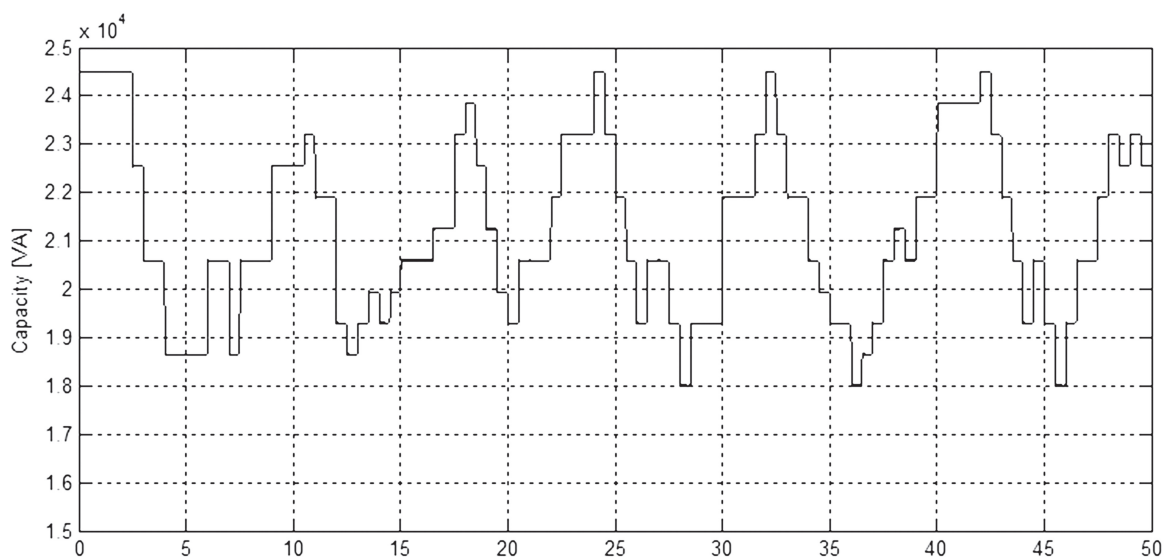

Fig 8. Loading of the 75 kVA transformer. Load variation is caused only by control system since both load and generation are modeled as constant

ping. On the bench model level avoided losses using proposed control method are 33.7% comparing to conventional voltage trip scenario. On the LV grid level, avoided losses are 68.7%. Control algorithm requires improvement in order to prevent premature power ups and excessive relay switching. Further research should include observation of control system in a more realistic environment using stochastic LV grid simulation. A coordinated control approach might be needed in order to equalize the losses among system owners, although in this particular setup it is showing a good level of ability to self-equalize without coordination between DG. Comparison against other voltage based PV output control systems should be investigated to get a better understanding of the value of proposed system.

This research is funded through Erasmus Mundus Joint Doctoral Programme SELECT+, the support of which is gratefully acknowledged.

References

- Attanasio R. 2012, *250 W grid connected microinverter*, ST Electronics.
- Bennich P., Persson A. 2006, *Methodology and first results from end-use metering in 400 Swedish households*, 4th International Conference on Energy Efficiency in Domestic Appliances And Lighting (EEDAL), Gloucester, UK.
- Dargatz M. 2010, *"Utility-Interactive": What it Means, What Protection it Ensures*, Enphase Energy technical report, Petaluma, CA, USA.
- Demirok E., Sera D., Teodorescu R., Rodriguez P., Borup U. 2010, *Evaluation of the voltage support strategies for the low voltage grid connected PV generators*, Energy Conversion Congress and Exposition (ECCE), doi:10.1109/ECCE.2010.5617937.
- IEA-PVPS 2008, *Community-Scale Solar Photovoltaics :Housing and Public Development Examples*, International Energy Agency IEA-PVPS T10-04: 2008.
- Lee D., Raichle B. 2012, *A side-by-side comparison of micro and central inverters in shaded and unshaded conditions*, World Renewable Energy Forum, Denver, USA.
- Paatero J.V., Lund P.D. 2007a, *Impacts of energy storage in distribution grids with high penetration of photovoltaic power* International Journal of Distributed energy Resources vol. 3, no. 1, pp. 31–45.
- Paatero J.V., Lund, P.D. 2007b *Effects of large-scale photovoltaic power integration on electricity distribution networks*, Renewable Energy vol. 32, pp. 216–234.
- SMA 2010, *PV Inverter Sunny Boy US User Manual*, SMA America LLC, Denver, USA.
- Thomson M., Infield D.G. 2007, *Impact of widespread photovoltaics generation on distribution systems*, Renewable Power Generation, doi:10.1049/iet-rpg:20060009.
- Tonkoski R., Lopes L.A.C. 2011, *Impact of active power curtailment on overvoltage prevention and energy production of PV inverters connected to low voltage residential feeders*, Renewable Energy, doi:10.1016/j.renene.2011.05.031.
- Tonkoski R., Turcotte D., EL-Fouly, Member T.H.M. 2012, *Impact of High PV Penetration on Voltage Profiles in Residential Neighbourhoods*, IEEE Transactions on Sustainable Energy, doi:10.1109/TSTE.2012.2191425.
- Ueda Y., Kurokawa K., Tanabe T., Kitamura K., Sugihara H. 2008, *Analysis Results of Output Power Loss Due to the Grid Voltage Rise in Grid-Connected Photovoltaic Power Generation Systems*, IEEE Transactions on Industrial Electronics, doi:10.1109/TIE.2008.924447.
- Viawan F.A. 2006. *Steady State Operation and Control of Power Distribution Systems in the Presence of Distributed Generation*, Department of Electric Power Engineering, Chalmers University of Technology, Gothenburg, Sweden.
- Walla T., Widén J., Johansson J., Bergerland C. 2012, *Determining and increasing the hosting capacity for photovoltaics in Swedish distribution grids*, 27th European Photovoltaic Energy Conference (EU-PVSEC), doi:10.4229/27thEUPVSEC2012-6DO.12.3.
- Widén J., Wäckelgård E., Lund P.D. 2009, *Options for improving the load matching capability of distributed photovoltaics: Methodology and application to high-latitude data*, Solar Energy, doi:10.1016/j.solener.2009.07.007.
- Widén J., Wäckelgård E., Paatero J., Lund P. 2010, *Impacts of distributed photovoltaics on network voltages: Stochastic simulations of three Swedish low-voltage distribution grids*, Electric Power Systems Research, doi:10.1016/j.epr.2010.07.007.