

# Recycling of Dispersed Metal Wastes in Rotary Furnaces

Sergei Leonid Rovin<sup>a\*</sup>, Alexander Sergei Kalinichenko<sup>b</sup> , Leonid Efim Rovin<sup>c</sup>

<sup>a</sup> UE “Technolit”, Ya. Kolasa Str., 24, Minsk, 220013, Republic of Belarus

<sup>b</sup> Belarusian National Technical University, Nezavisimosty Ave. 65, Minsk, 220013, Republic of Belarus

<sup>c</sup> Sukhoi State Technical University of Gomel, Prospect Octiabria 48, Gomel, 246746, Republic of Belarus

\*e-mail: [technolit@tut.by](mailto:technolit@tut.by)

Received: 13 May 2019/Accepted: 11 July 2019/Published online: 31 July 2019

This article is published with open access by AGH University of Science and Technology Press

---

## Abstract

The recycling of dispersed metal containing wastes is a considerable problem, as their accumulation in dumps today is commensurate with the volume of ore extraction. Several methods and technologies are developed to recycle metal containing wastes but almost all of them require the preliminary preparation of wastes resulting in an increased price of the recycled metals. Furthermore, it is especially difficult to recycle dispersed multicomponent wastes and, therefore, the problem of developing effective, flexible and reliable technology for recycling of dispersed metal containing wastes is still a pressing one.

The article presents an alternative method of recycling dispersed iron-containing wastes based on a continuous solid-liquid process of iron oxides reduction in rotary tilting furnaces (RTF). The new method allows the processing of waste of almost any composition and state: from metal lumps to oxide and multicomponent (chips, scale, sludge, etc.) wastes, contaminated with moisture, oils, organic impurities without their preliminary preparation (cleaning, homogenization, pelletizing, etc.). The result of recycling is the production of cast iron or steel ingots or required casting alloys. Some features of technology are considered, including the gas flow and motion of charge metal particles within the RTF. Process parameters providing high metal output are established.

## Keywords:

recycling, dispersed metal wastes, rotary tilting furnaces, heat and mass exchange, mix, reduction

---

## 1. INTRODUCTION

In conditions of a growing shortage of high-quality charge materials and their rising prices, the recycling of dispersed iron-containing wastes (chips, scale, aspiration and abrasive dust, sludge, etc.) has become particularly important as their accumulation in dumps today is commensurate with the volume of ore extraction, and poses a serious environmental threat [1].

Traditional melting units in foundries and metallurgical plants are not adapted to the melting of dispersed materials. Therefore, almost all well-known recycling technologies of dispersed metal waste require their preliminary agglomeration (briquetting, balling etc.). However, briquetting of even the most valuable part of these wastes (steel and cast iron chips) does not allow charging material to be obtained that meets the quality of dense lump scrap [2, 3].

Before processing, metal wastes undergo multistage preliminary preparation, the cost of which reaches 60–80% of the resulting metal cost. A new concept of recycling is based on a flexible low-tonnage technology and equipment that allows cost-effective processing of relatively small amounts of heterogeneous waste in their initial state without preparation and pelletizing, resulting in the production

of high-quality charge materials or alloys. The implementation of this process is carried out by means of rotary tilting furnaces (RTF) with a controlled gas flow vector and an inclined axis of rotation, providing higher heating rate and lower dust losses compared to traditional direct-flow drum furnaces [4, 5].

The developed technology is based on the intensification of physical and chemical processes due to the processing of individual particles of the material with a characteristic particle size of not more than 1–3 mm and typified by a developed reaction surface and porosity. These features allow a tenfold increase in the rate of heating, recovery and melting processes [4].

The study of the properties of dispersed metal waste, the study of solid- and liquid-phase reduction processes, operating and design characteristics of rotary furnaces using simulation and computer simulation, field experiments allowed the development of the theoretical and technological basis of flexible, cost-effective, low-tonnage recycling and introducing it into production. This opens up the possibility for foundry shops and machine works to create their own raw material base for foundry production. Moreover, it is possible to organize a waste-free system of metal turnover in machine-building enterprises.

## 2. FEATURES OF DISPERSED MATERIAL MOTION AND GAS FLOW IN THE RTF

More than 60% of all technogenic metal wastes are dispersed materials: shavings, slag, sludge, abrasive and aspiration dust etc. Lumps of dense scrap have long been used as a valuable charging material and processing them is not difficult. The situation with the remelting of dispersed metal wastes, particularly the oxide and multi-components ones, is rather different as to date no technology has been developed to the proper degree. Losses are up to 50% in cupolas or electric furnaces when melting dispersed materials (even the most valuable part of such waste – chips) run without their preliminary preparation due to entrainment and fumes. Cold briquetting of chips does not allow high-quality charge materials to be obtained. Better quality briquettes are obtained by pre-cleaning, sorting, adding binders and reductants with further high-temperature heating and pressing under high specific pressure. But even in this case the briquettes do not correspond to the quality of dense lump scrap despite often costing more to produce.

It is known that a significant acceleration of heat and mass transfer processes, including transfer of gaseous reducing agents CO and H<sub>2</sub> deep into the particles, can have an impact. As a result, the role of direct reduction during the treatment of dispersed porous materials becomes stronger due to the increase of the reaction surface. To realize this effect, it is necessary to purge the layer of dispersed particles with a gas – heat carrier-reducing agent. It can be done in installations with a "boiling layer" or in a pneumatic stream for mono-dispersed material. For poly-dispersed metal waste, effective mass transfer can only be arranged by mixing the material itself, and this can be achieved most easily in rotating drum units (so-called short-drum furnaces are used for melting). However, there are restrictions in straight-through furnaces on the speed of the gas-heat carrier motion which cannot exceed the flying speed of heated material's particles (usually 3–5 m/s), which does not allow a high heat transfer coefficient to be obtained

$\alpha = f(\text{Re}, \text{Nu}, \text{Pr})$ , where Re, Nu, Pr are Reynolds, Nusselt and Prandtl criterial numbers respectively. As a result, such furnaces are characterized by low thermal efficiency (not more than 10–15%) [5]. To increase the thermal efficiency of the rotary furnace there is a trend to make an increased length (to 40–160 m or more, e.g. tubular furnace). The heat balance is improved, but it is impossible to melt wastes in such furnaces as the process becomes poorly controlled.

Recently introduced rotary tilting furnaces with loop-like gas movement open up new possibilities in the processing of dispersed materials (Fig. 1).

The motion study of non-isothermal flow of gases in the RTF, the temperature fields and the intensity of heat exchange performed on full-scale units and by computer simulation allowed us to determine that the movement of gases in such furnaces has a complex circulation in nature. The speed of rotation is significantly higher (5–8 times) than the translational speed of the flow, resulting in increases in gas residence time in the working space and higher efficiency of heat transfer. Moreover, losses of dispersed and ultradispersed particles become lower [6].

The study of the gas flows was performed by applying a 3D-model of the furnace created in SolidWorks 14.0 and divided by ANSYS Meshing into a grid with the number of elements equal to 290,665. The results of numerical simulation are temperature fields, velocity and trajectory of the gas flow. Examples of the results obtained are shown in Figure 2 [6].

The aerodynamics of the flow and its interaction with the material depends on the location of the burners, their number and angle of attack as well as the layer configuration. The direction of rotation can be changed under certain conditions.

A simulation technique to study the nature and features of dispersed materials movement in the RTF was developed. The model was realized on the basis of hydrodynamic similarity principles. It was found that the dispersed materials in the RTF make a helical reciprocating motion which provides active mixing of the dispersed material both in the radial and axial direction.

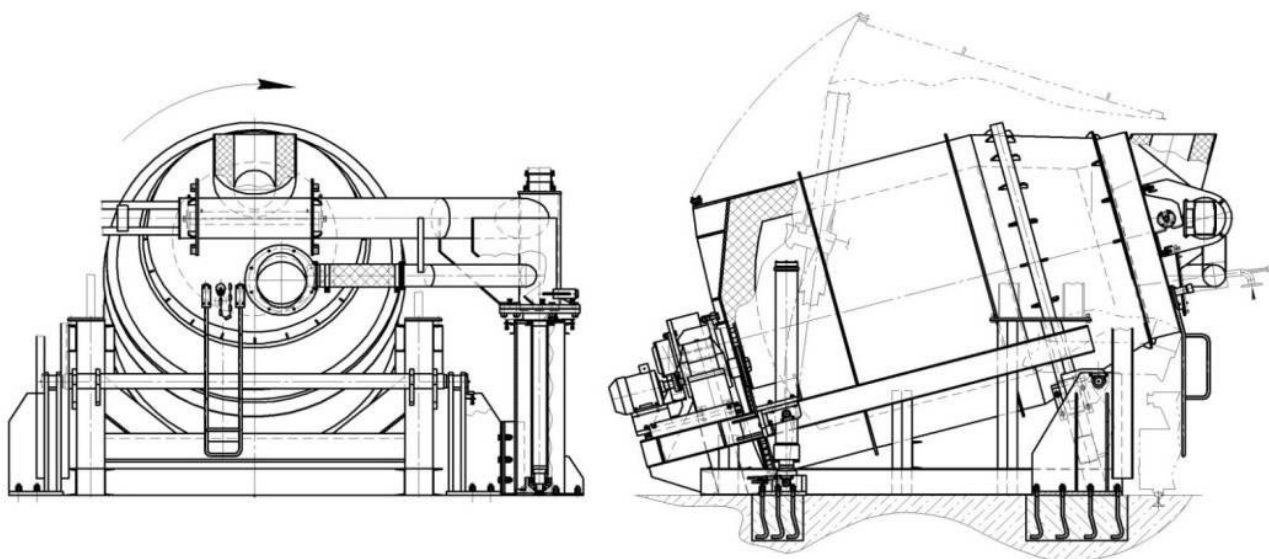

Fig. 1. General view of the RTF with loop-like movement of gases developed by UE "Technolit"

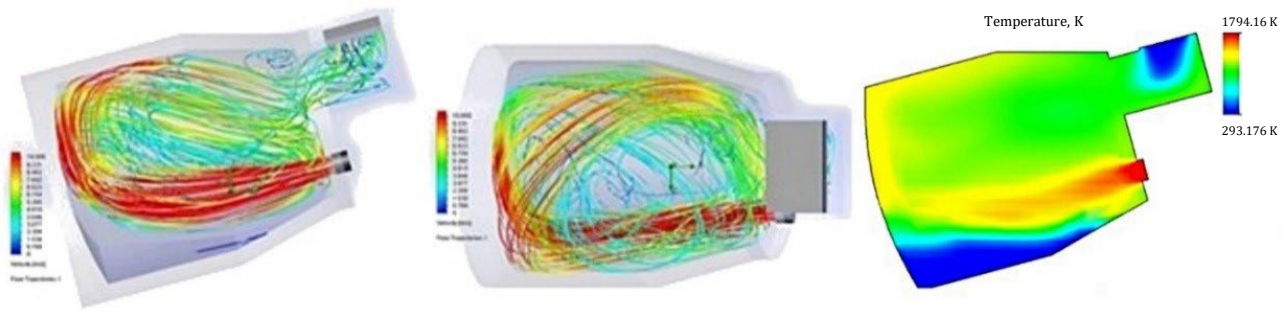

Fig. 2. The trajectory and velocity of gas movement as well as temperature fields in the RTF

The speed of material’s “rotation” in the cross section exceeds the rotation speed of the furnace by 2–3 times and depends on the adhesion and autoadhesion properties of the material and the relative volume of the furnace charge.

Computer simulations were carried out using software CD-Adapco Star CCM+, Promotech Particle Work and the method of discrete (finite) elements DEM (Discrete Element Method) to determine the quantitative characteristics of the movement both the layer and individual particles of the material in the RTF. These data are necessary to obtain the real parameters of heat and mass transfer for further calculation and the design of furnaces. The calculations were performed on the basis of the instantaneous balance of gravity, inertia and contact forces of the particles considered with other particles and the furnace surface. The particles are considered as solid and elastic bodies and their size is determined by the data of field experiments, taking into account the scale factor. The particles undergo translational and rotational motion. Calculations take into account also the forces of adhesion and auto-adhesion [7–9]. As a result of the numerical simulation, data

about the nature of the dispersed materials movement in rotary furnaces with an inclined axis of rotation, the layer structure, trajectories and velocities of individual particles were obtained for the first time. The mixing process in the dynamic layer was investigated as well.

The velocities of the particles in the center and on the periphery of the layer may differ by tens or even hundreds of times, but there is no clear boundary between the zones. In addition, the absolute values and the velocity distribution vary over time and depending on the distance of the cross section relative to the bottom or neck of the furnace. Aerodynamic forces of high-speed gas flow affect the top layer of particles, especially in the collapse. In the cross section, the dynamic layer becomes lentil-shaped. Some results of the modeling of the material motion in the RNP are shown in Figures 3–5 [10].

In accordance with the fact that the heat transfer by convection occurs under conditions of macro-volumes mixing, the obtained data on the mixing velocities in the RTF allow us to calculate the volumetric heat transfer coefficient in the layer ( $\alpha_v$ ).

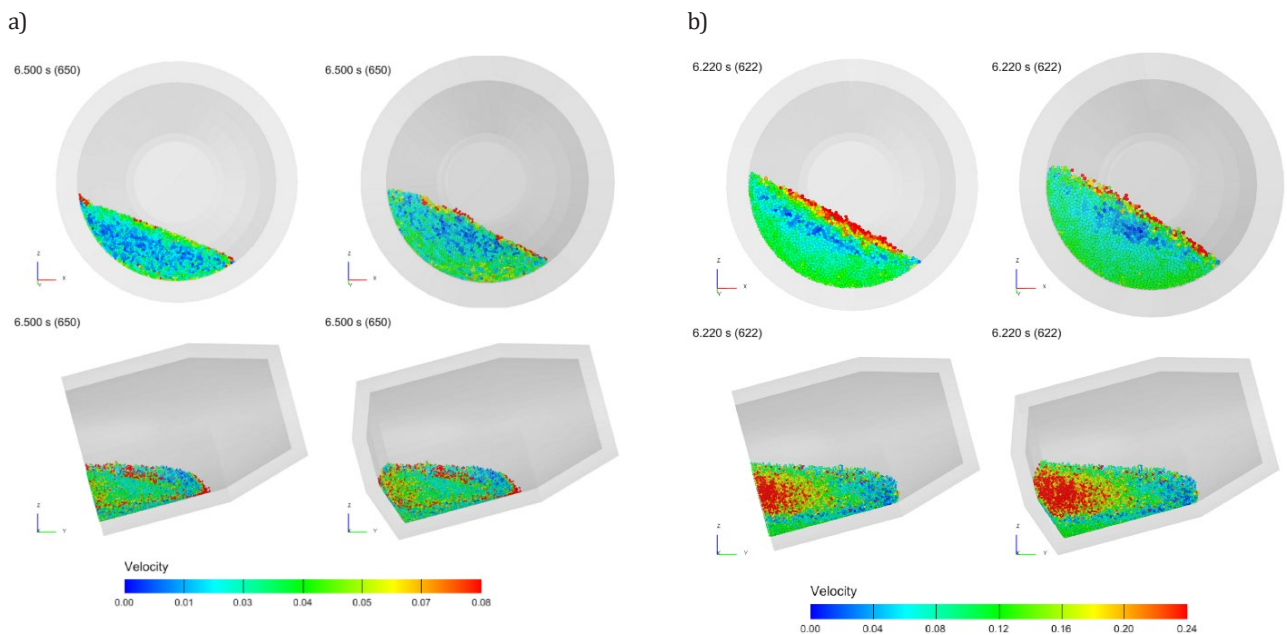
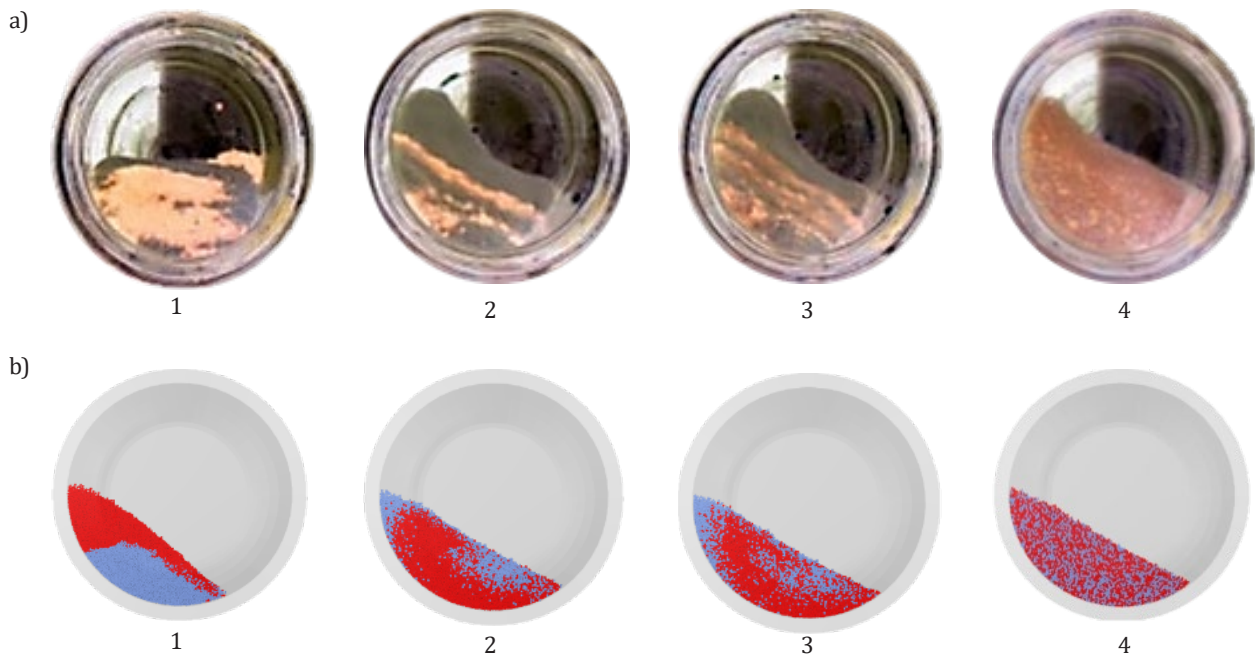
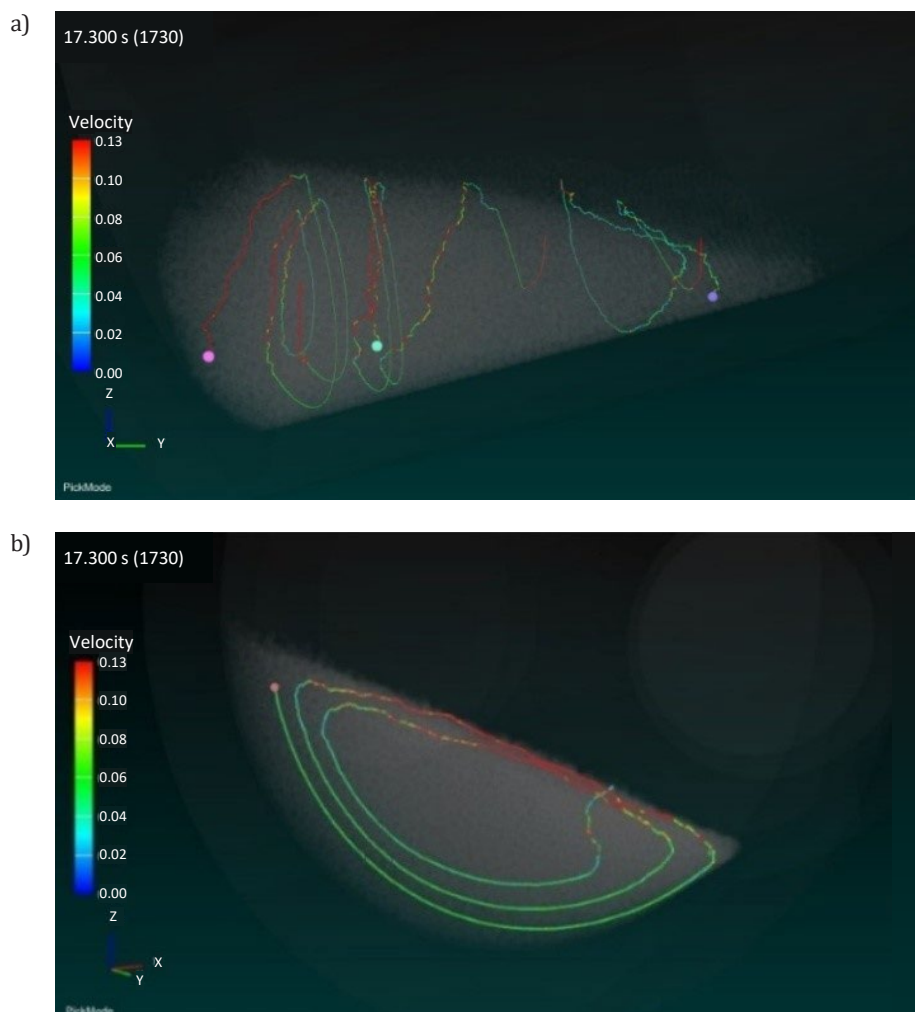

Fig. 3. The distribution of dispersed particles velocities in the layer of material in the RTF: a) rotation of the furnace at a speed of 5 rpm; b) rotation of the furnace at a speed of 10 rpm



**Fig. 4.** Mixing of the material in the RTF: a) simulation modeling; b) computer simulation: 1 – the beginning of the rotation; 2 – one revolution of the housing; 3 – two turns; 4 – six turns



**Fig. 5.** The trajectory of the dispersed material particles in the RTF: a) longitudinal direction; b) cross-section

The heat balance, taking into account the heat loss with the exhaust gases, determines the heat consumption for heating the material to a predetermined temperature and at the same time the heat energy consumption by the heat carrier gas.

The calculated values for the experimental conditions (for the stirred blown layer) are  $\alpha_v = 2750\text{--}3100 \text{ W/m}^3$ , which are almost 3 orders of magnitude higher in comparison to the heating of the stationary layer.

The results of the simulation and numerical simulation of gases and dispersed materials motion under non-stationary conditions served as the basis for the development of technical solutions aiming at the intensification of rotary furnaces. Rotating tilting furnaces of different design and with controlled gas flow vector have been successfully implemented in practice. The created units allow working effectively with dispersed waste of both ferrous and non-ferrous metals. The efficiency of furnaces reaches 50–55%, which is 3–5 times higher compared to electric induction, arc or stationary fuel furnaces when working on such materials.

The obtained results on the processes of movement and mixing of dispersed materials can also be used for the calculation and modernization of mixers for various purposes, painting chambers, cladding installations and other rotating type units.

### 3. HEATING AND REDUCTION OF DISPERSED MATERIALS IN RTF

Unlike traditional installations, working with a fixed layer of lump materials, in the RTF material makes a continuous helical reciprocating motion, actively mixing, and constantly interacting with a high-speed turbulent gas flow, making a loop-like motion in the working space of the furnace [6].

Constant updating (mixing) of the layer and its intensive purging greatly accelerate the heat transfer processes. The small particle size of the material layer (from  $3 \cdot 10^{-2}$  to  $1 \cdot 10^{-4}$  m) as well as the porosity and microporosity of oxide particles (up to 0.05–1.0  $\mu\text{m}$ ) make the main contribution in high intensity of the heating process. Accordingly, the area of the reaction surface of a dispersed particles layer (e.g. scale) is 0.5–2.5  $\text{m}^2/\text{g}$ .

Heating the chips or forging scale to a temperature of 750–850°C in the industrial RTF with a capacity of 2–4 tons took 15–18 minutes using a natural gas burner with a capacity of 1.0 MW. Natural gas consumption ranged from 11 to 14  $\text{m}^3/\text{t}$  for clean dry charge and 8–10  $\text{m}^3/\text{t}$  for heating the chips contaminated with oils. Heating of iron-containing materials must be carried out at high speed and in an oxidation-free atmosphere. Dispersed wastes containing carbon (coke, coal, lignin) are loaded into the furnace, providing the formation of an oxidation-free atmosphere. Basically high temperature oxidation-free heating of the chip is commonly applied in a duplex process RTF-induction crucible furnace. This process allows a reduction of electricity consumption for 180–220  $\text{kW}\cdot\text{h}/\text{t}$  and up to 30–35% of the melting time.

The recycling of oxide iron containing materials is a more difficult and complicated process. The reduction of oxides is almost impossible in traditional melting furnaces of

foundry shops (cupolas, induction and arc furnaces). It is proved by half a century of unsuccessful experiments with the organization of reduction cupola melting with the help of composite briquettes containing various reducing agents [3]. In contrast to the above mentioned furnaces, the RTF allows the entire cycle of oxide metal waste processing to be carried out consistently: drying, removal of contaminants, heating, pre-reduction in the solid phase and then rapid transfer of the material into the liquid phase, the final liquid phase reduction and refinement of the melt to a given composition (grade). The recovery effect reaches a level close to a theoretically possible one. As a result, both steel and cast iron can be obtained from iron-containing waste. This is a tremendous advantage of the technology developed compared to usual metallurgy, where the process ends at the stage of sponge iron: metallized pellets or briquettes. In RTF, reaction surface increases and the speed of heating, reduction and melting processes increases tenfold. The "Quasi-homogeneous" model of the reduction process can adequately describe the physical-chemical processes of dispersed porous materials reduction (scale, aspiration dust or metallurgical slurries). The model is based on the idea that the reducing agent penetrates and interacts with oxides throughout the cross section of particles. The speed of the process is the same and metallization occurs throughout the volume of the particles (layer element) at the same time. The degree of metallization reaches 75–80% after 30 minutes for reducing scale in a dynamic layer at a temperature of 1100–1200°C [4, 6].

The recycling process in the RTF is carried out as follows. The initial charge (iron-containing waste, reducing agent and fluxes) is loaded into the furnace filling 28–30% of the working volume without any preliminary preparation. Heating with gas or liquid fuel with a specific flow rate of 12–15  $\text{m}^3/\text{t}$  is carried out when the furnace rotates at a speed of 3–5 rpm. When the temperature reaches 1000–1100°C charge is maintained for 1.5–2.0 hours (depending on the mass of the material) for the solid-phase reduction stage. At the same time, the furnace maintains a reducing atmosphere:  $\text{CO}/\text{CO}_2 = 1.5\text{--}2.5$ . At the end of the period there are small spherical granules of sponge iron. The degree of Fe reduction reaches 80–85%. Then, fluxes, reducing agent and additives are additionally loaded into the furnace and oxygen is supplied resulting in a temperature increase in the working space to 1700–1800°C. The rotation speed decreases to 0.5–1.0 rpm. Within 5–6 minutes, the process is moved to the stage of liquid-phase reduction (LPR), virtually bypassing the stage of screaming recovery. The duration of the LPR stage does not exceed 20–30 minutes depending on the requirements for the liquid metal, primarily to the carbon concentration in it. Then the metal is exposed until the end of the bale and merged into molds or ladle for secondary treatment. The flow rate of the reducing agent is within 40% of the mass of oxides (depending on their composition). Consumption of gas fuel is 120–130  $\text{m}^3$  per ton of scale and oxygen 25–30  $\text{m}^3/\text{t}$ . Resulting iron-carbon alloys depending on the liquid phase reduction mode can be treated to a given composition and quality of branded alloys (cast iron and steel) [11]. However, more rational

is the use of RTF to produce high-quality charge material (ingots, pigs) for the subsequent smelting of branded alloys in traditional furnaces. For machine-building enterprises it is more attractively the organization of a duplex process, in which the metal obtained in RTF directly in liquid form is transferred to traditional electric smelting units or mixer to obtain the required chemical composition and exposition at a given temperature [4, 12].

During the reduction melting of scale and sludge, the duration of the SPR-process did not exceed 2.0–2.5 hours, and the entire cycle, including liquid-phase recovery to 95–99% and treatment to a predetermined composition was no more than 3–3.5 hours.

The technological intervals of obtaining iron-carbon alloys in the RTF in comparison with the known processes of iron direct reduction are shown in Figure 6.

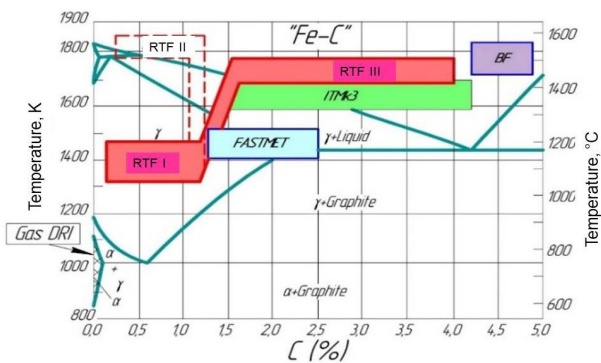

Fig. 6. Technological intervals of production of iron-carbon alloys in RTF

The process can also be used for recycling non-ferrous alloys, which has been verified by full-scale tests and subsequent implementation in the processing of lead, aluminum and copper alloys. Figure 7 shows examples of RTF for the recycling of a different dispersed metal wastes.

The developed technology and equipment, due to its technological flexibility, allows the use of waste of any composition, degree of contamination (including with oils and coolant), degree of oxidation (including scale and sludge),

heterogeneity of properties and characteristics in a wide range of volumes starting from several hundred kilograms and up to two dozen tons in one charge, which ensures good adaptation to the conditions of existing production and does not require large investments in development.

The profitability of production shops in machine-building enterprises for processing their own dispersed metal waste is not less than 50%, and the return on investment is no more than 9–12 months. The production capacity of such shops can range from 0.5–1.0 thousand to 50–100 thousand tons of metal waste processed annually.

#### 4. SUMMARY

The new concept of recycling based on flexible low-tonnage technology and special equipment allows cost-effective processing of relatively small amounts of heterogeneous waste in the initial state without preliminary preparation and pelletizing aimed at obtaining high-quality charge materials or alloys for foundries. The developed technology is based on the characteristic features of physical and chemical processes and heat-mass transfer in the transition to the processing of material particles with a characteristic particle size of not more than 1–3 mm which are characterized with a developed reaction surface and porosity. As a result, it allows the speed of heating, reduction and melting processes to be increased tenfold.

Implementation of the technology is carried out applying rotary tilting furnaces with an inclined axis of rotation and controlled gas flow vector. Studies of the movement of non-isothermal gases flows and dispersed materials in the RTF, temperature fields and heat exchange intensity allowed the determination of the optimal design parameters of these furnaces and to develop recommendations for their design and operation.

The solution of the problem of ferrous and non-ferrous metals' dispersed wastes recycling opens up the possibility of the creation of one's own raw material base for a foundry. Moreover, it is possible to organize a waste-free system of metal turnover, improve the environmental situation and reduce the production costs of metal engineering and metalworking enterprises.

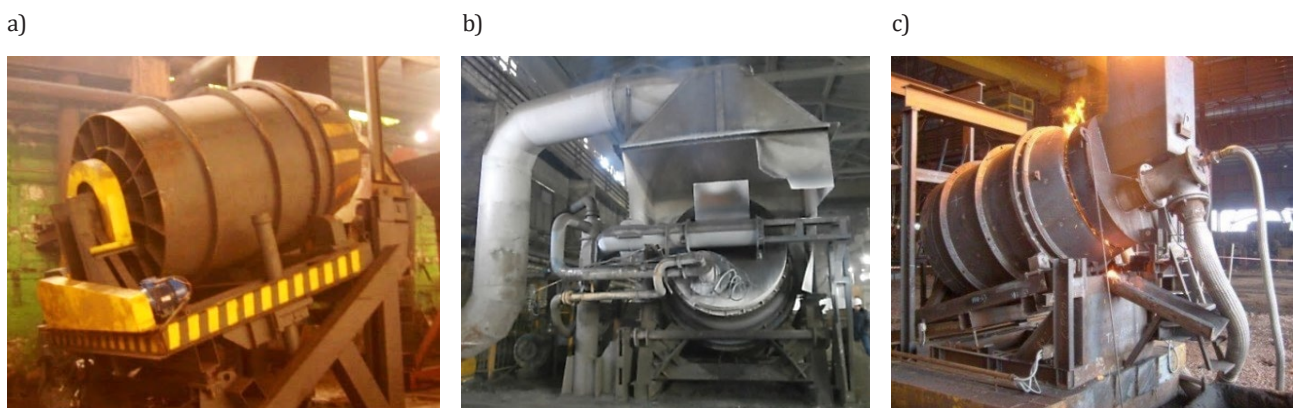

Fig. 7. Rotary tilting furnace for the recycling of dispersed metal wastes manufactured by UE "Technolit": a) processing of cast iron shavings (GLS Tsentrolit, Gomel); b) recycling lead ("CPWR ALLOY", Ryazan, Russia); c) recycling of iron scale and sludge ("BMZ", Zhlobin)

## REFERENCES

- [1] *Recovering metals from waste*. Retrieved from: <https://www.metso.com/industries/waste-recycling/waste-types/metals/> (accessed 17.08.2018).
- [2] Valavin V., Makeev S., Pokhvisnev Yu., Zaytsev A. & Popov A. (2012). Recycling of Iron-Containing Waste of Metallurgical Works in the Countries of Black Sea Economic Cooperation (BSEC). *IX International Congress "Machines, Technologies, Materials"*, 1, 79–81.
- [3] Bogdandy L. & Engell H.-J. (2013). *The Reduction of Iron Ores – Scientific Basis and Technology*. Berlin: Springer/Link.
- [4] Rovin S.L. (2015). *Retsikling metallootkhodov vrotatsionnykh pechakh*. Minsk: Belorusskiy Natsional'nyu Tekhnicheskiy Universitet [Ровин С.Л. (2015). *Рециклинг металлоотходов вращающихся печей*. Минск: Белорусский Национальный Технический Университет].
- [5] Schmitz C. (2003). *Handbook of Aluminium Recycling*. Essen: Vulkan-Verlag GmbH.
- [6] Rovin S.L. (2016). Issledovaniye raboty rotatsionnykh naklonuyushchikhsya plavil'nykh pechey. *Nauka i Tekhnika*, 15(1), 18–28 [Ровин С.Л. (2016). Исследование работы ротационных наклоняющихся плавильных печей. *Наука и Техника*, 15(1), 18–28]. Doi:10.21122/2227-1031-2016-15-1-18-28.
- [7] Warnatz J., Maas U. & Dibble R.W. (2006). *Combustion. Physical and Chemical Fundamentals, Modeling and Simulation, Experiments, Pollutant Formation*. Berlin: Springer-Verlag Berlin Heidelberg GmbH.
- [8] Sonavane Y. & Specht E. (2008). Numerical analysis of the heat transfer in the wall of rotary kiln using finite element method ANSYS. *7<sup>th</sup> International Conference on CFD in the Minerals and Process Industries: December 9–11. Melbourne, Australia*. CSIRO, 1–5.
- [9] Norouzi H.R., Zarghami R., Sotudeh-Gharebagh R. & Mostoufi N. (2016). *Coupled CFD-DEM modeling: formulation, implementation and application to multiphase flows*. Chichester: John Wiley & Sons.
- [10] Rovin S.L., Rovin L.E., Zharanov V.A. & Mazurov V.S. (2017). Dvizheniye i smeshivaniye dispersnykh materialov vrotatsionnykh pechakh. *Lit'ye i metallurgiya*, 2, 117–127 [Ровин С.Л., Ровин Л.Е., Жаранов В.А. & Мазуров В.С. (2017). Движение и смешивание дисперсных материалов в ротационных печях. *Литье и металлургия*. 2, 117–127]. Doi:10.21122/1683-6065-2017-2-117-127.
- [11] Rovin S.L. & Kalinichenko A.S. (2017). Primeneniye rotatsionnykh naklonuyushchikhsya pechey dlya organizatsii bezotkhnogo oborota metallov na mashinostroitel'nykh predpriyatiyakh i proizvodstva otlivok. *ITB "Lit'ye Ukrainy"*. 8 (204), 2–8 [Ровин С.Л. & Калиниченко А.С. (2017). Применение ротационных наклоняющихся печей для организации безотходного оборота металлов на машиностроительных предприятиях и производства отливок. *ИТБ "Литье Украины"*, 8 (204), 2–8].
- [12] Negami T. (2000). Premium iron shot making by ITmk3. Commercializing new hot metal processes beyond the blast furnace. *Gorham conference proceeding. Atlanta, Georgia, USA*, 171–176.