

ŁUKASZ T. STĘPIEŃ*

APPLICATION OF WATERLOO MAPLE 9.5 AND WOLFRAM MATHEMATICA 5.1 SOFTWARE FOR ANALYTIC SOLVING OF CERTAIN NONLINEAR PARTIAL DIFFERENTIAL EQUATIONS OF PHYSICS

In the current paper some applications of the packet MAPLE (v. 9.5) for analytic solving of certain nonlinear partial differential equations have been presented. Additionally, for graphic presentation of the found solutions packet MATHEMATICA (v. 5.1) has been applied.

Keywords: nonlinear partial differential equations, analytic solutions, exact solutions, Navier-Stokes equation, Monge-Ampere equation, steady isentropic flow equation

ZASTOSOWANIE PAKIETÓW MAPLE 9.5 ORAZ MATHEMATICA 5.1 DO ANALITYCZNEGO ROZWIĄZYWANIA WYBRANYCH NIELINIOWYCH RÓWNAŃ RÓŻNICZKOWYCH CZĄSTKOWYCH FIZYKI

W niniejszej pracy zostały przedstawione zastosowania pakietu MAPLE (wersja 9.5) do analitycznego znajdowania rozwiązań wybranych nieliniowych równań różniczkowych cząstkowych. Do prezentacji graficznej tych rozwiązań użyto pakietu MATHEMATICA (wersje 5.1).

Słowa kluczowe: nieliniowe równania różniczkowe cząstkowe, rozwiązania analityczne, rozwiązania dokładne, równanie Naviera-Stokesa, równanie Monge'a-Ampere'a, równanie stałego przepływu izentropowego

1. Introduction

Nonlinear partial differential equations (NPDE's) give a description of many interesting and important phenomena in physics. Some examples may be: Einstein equations

* Pedagogical University in Krakow, Department of Computer Sciences and Computer Methods, ul. Podchorążych 2, 30-084 Krakow, Poland, lstepien@ap.krakow.pl, lstepien@inf.ap.krakow.pl, stepien50@poczta.onet.pl

in General Relativity or Navier-Stokes equations. There exist some powerful analytic methods of solving such equations: Bäcklund transformation method [6], [4], symmetry analysis method, [2], [4], a concept of strong necessary conditions [5], [6], extended homogeneous balance method, [1], etc. However, it is possible they will not give all solutions of investigated equation. The applied method, firstly presented in [7], gives an opportunity for finding some wide classes of the solutions of certain NPDE's. Presentation of examples of application of this method for some such equations, is the main aim of this paper. This paper is organized as follows. In the next section we show the equations, which we want to solve. In section 3 we present shortly the method. Section 4 is devoted to show the results of applying of the mentioned method for several NPDE's. In section 5 some conclusions are included.

2. The equations

2.1. Euler and Navier-Stokes equation in dimensions (2+1)

Navier-Stokes equation has a form (for a plane flow), [4]:

$$(\Delta u)_{,t} + u_{,y}(\Delta u)_{,x} - u_{,x}(\Delta u)_{,y} = n\Delta\Delta u, \quad u \in R \quad (1)$$

where $u \in R$ is a stream function and n is a viscosity coefficient. Euler equation describes the flow of an ideal fluid, so in its case: $n = 0$.

2.2. Homogeneous Monge-Ampere equation in the dimensions (3+1)

This equation has the following form, [2]:

$$\det(u_{\mu\nu}) = 0 \quad (2)$$

where $u \in R$, $u_{\mu\nu} = \frac{\partial^2 u}{\partial x^\mu \partial x^\nu}$, $\mu, \nu = 0, 1, 2, 3$.

2.3. Equation of steady isentropic flow in the dimensions (2+0)

This equation has the form, [4]:

$$\left(g^2 - \left(\frac{\partial u}{\partial x} \right)^2 \right) \frac{\partial^2 u}{\partial x^2} - 2 \frac{\partial u}{\partial x} \frac{\partial u}{\partial y} \frac{\partial^2 u}{\partial x \partial y} + \left(g^2 - \left(\frac{\partial u}{\partial y} \right)^2 \right) \frac{\partial^2 u}{\partial y^2} = 0, \quad (3)$$

where $u \in R$ is a velocity potential and $g = g\left(\left(\frac{\partial u}{\partial x}\right)^2 + \left(\frac{\partial u}{\partial y}\right)^2\right)$ is a sound speed. We investigate the case, when $g = \sqrt{\left(\frac{\partial u}{\partial x}\right)^2 + \left(\frac{\partial u}{\partial y}\right)^2}$.

3. An algorithm

3.1. Decomposition method

We want to find certain analytic solutions of some NPDE, [7]:

$$F(x^\mu, u_1, \dots, u_m, u_{1,x^\mu}, u_{1,x^\mu x^\nu}, \dots, u_{m,x^\mu}, u_{m,x^\mu x^\nu}, \dots) = 0, \tag{4}$$

$$\mu, \nu = 0, 1, 2, 3,$$

where $m \in N$ and u is in general an unknown function of class C^k , $k \in N$.

Let's limit in this introduction to the case: $m = 1, k = 2$. We apply the following procedure, [7]:

I. we check, whether there is possible to make a decomposition of this equation into such fragments, which are characterized by a homogeneity of the derivatives of the unknown function u . "Homogeneity of the derivatives": these fragments should be products of at least two factors:

- a. arbitrary expression, which may depend on the unknown function u , its derivatives and the independent variables (in general: x^μ , $\mu = 0, 1, 2, 3$),
- b. a sum of: at least two derivatives and (or) at least two products of the derivatives, so that there we can find for any derivative and (or) any product some other derivative and (or) other product, which has the same order and (or) degree.

II. For example, the investigated equation may be as follows:

$$F_1 \cdot [(u_{,x})^2 + (u_{,y})^2] + F_2 \cdot [u_{,xx} + u_{,xy}] = 0, \tag{5}$$

where F_1 and F_2 may depend on x^μ , u , $u_{,x^\mu}$, ...

III. We insert some ansatzes, presented below. We collect all algebraic terms, appearing by all derivatives of f and require vanishing of them.

3.2. Ansatzes

1. The ansatz of first kind This ansatz has the form, [7]:

$$u(x^\mu) = \beta_1 + f(a_\mu x^\mu + \beta_2, b_\nu x^\nu + \beta_3, c_\rho x^\rho + \beta_4), \tag{6}$$

where: $v_\alpha x^\alpha = -v_0 x^0 + v_k x^k$, $k = 1, 2, 3$. The parameters a_μ, b_μ, c_μ , $\mu = 0, 1, 2, 3$, are some constants to be determined later, β_j , $j = 1, \dots, 4$, are arbitrary constants and $x^\mu \in R$. As well is in the case of combined ansatz.

2. The ansatz of second kind This ansatz is as it follows, [7]:

$$u(x^\mu) = \beta_1 + f(A_0 x^0 x^1 + A_1 x^0 x^2 + A_2 x^0 x^3 + A_3 x^1 x^2 + A_4 x^1 x^3 + A_5 x^2 x^3 + \beta_2) \tag{7}$$

where A_λ , $\lambda = 0, 1, \dots, 5$ are some constants to be determined later, β_j , x^μ are as in the case of first ansatz.

3. The combined ansatz The form of this ansatz is, [7]:

$$u(x^\mu) = \beta_1 + f(a_\mu x^\mu + \beta_2, A_0 x^0 x^1 + A_1 x^0 x^2 + A_2 x^0 x^3 + A_3 x^1 x^2 + A_4 x^1 x^3 + A_5 x^2 x^3 + \beta_2), \quad (8)$$

where $a^\mu, \dots, A^\lambda, \beta_j, \mu = 0, 1, 2, 3, \lambda = 0, \dots, 5$ and x^μ are as in the cases of first and second ansatz.

Some important remarks:

1. These all ansatzes have a common feature: they contain some *arbitrary* function f of some appropriate arguments. It is the function of class C^2 . We want to find wide class of the solutions as far as possible.
2. Of course, the number of the variables x^μ in these ansatzes depends on the investigated equation.
3. The notation, concerned to the investigated equations, is: $x^0 = t, x^1 = x, x^2 = y, x^3 = z$.
4. If the specification of the investigated equation requires that u has to be real function and from the further computations we obtain complex values of the coefficients a_μ, \dots, A_λ , then we try to apply such ansatz:

$$u(x^\mu) = \beta_1 + \Re(f),$$

where the dependence of the function f on the independent variables x^μ is given by the ansatz.

3.3. Applied software and hardware

All computations and figures were done on the computers: SunFire 6800 (“saturn” in ACK-CYFRONET-AGH in Kraków), by using Waterloo MAPLE 9.5 Software and Wolfram MATHEMATICA 5.1 Software respectively, (grant No. MNiI/Sun6800/WSP/008/2005) and IBM Blade Center HS21 “mars”, by using Waterloo MAPLE 12 Software, (grant No. MNiSW/IBM BC HS21/AP/057/2008). All the mentioned computations were symbolic. The presented figures were made by applying a package “Graphics ’Animation”” and the function “MoviePlot3D” of MATHEMATICA 5.1 software.

4. Results of application of decomposition method by using MAPLE 9.5 and MATHEMATICA 5.1 software

4.1. Solutions – existence of them and values of the coefficients of the ansatzes

As a result of inserting of the above ansatzes into each of the investigated equations, we obtain some system of algebraic equations, where the unknown quantities are the coefficients a_μ, \dots, A_λ . We have got such system by using a MAPLE instruction

“collect”, thanks to it we can collect, according to the procedure, described in subsect. 3.1, all terms, which are by each derivative of the function f :

$$\text{collect}(\text{izentr}, [D[1](f), D[2](f), D[3](f), D[1, 1](f), D[1, 2](f), D[1, 3](f), D[2, 2](f), D[2, 3](f), D[3, 3](f)], \text{distributed});$$

where “izentr” is a name of an Maple input, which contains an expression, created by mentioned inserting of the ansatzes. Moreover, there some short notation has been used: $D[i](f)$, $D[i, j](f)$ denote i -th and ij -th derivative of the function f respectively. Next we equal such collected expression to zero and we obtain an algebraic equation. For example we give here a fragment of such system, obtained in the case of the ansatz of first kind (6), applied for the equation of isentropic flow (3):

$$(a_1 c_2 - a_2 c_1)^2 = 0, \tag{9}$$

$$(b_1 c_2 - b_2 c_1)^2 = 0 \tag{10}$$

If we can write down and solve such system for the investigated equation, we know the exact solution, given by the ansatz, which we applied previously. For solving such system of algebraic equations we have applied the MAPLE instruction “solve”. The values of the coefficients for each of the investigated equations have been collected in the Table 1.

Table 1

The values of the coefficients. The coefficients, appearing at the right sides of the formulas, are arbitrary real constants. However, of course, if they are the denominators, they must be nonzero constants

Equation	Solution of 1st kind	Solution of 2nd kind	Combined solution
Euler- and Navier-Stokes	unphysical solution: $a_2 = ia_1, b_2 = ib_1,$ $c_2 = ic_1$ (see subsect. 3.1 and some comments beneath)	the solution does not exist (see subsect. 3.1 and some comments beneath)	the solution does not exist (see subsect. 3.1 and some comments beneath)
Monge-Ampere	$a_\mu, b_\mu, c_\mu \in R -$ arbitrary	$A_0 \in R -$ arbitrary, $A_1 = \frac{A_2 A_3}{A_4}, A_5 = 0$	$a_3 \in R -$ arbitrary, $A_1 = \frac{a_2 A_0}{a_1},$ $A_4 = \frac{a_1 A_5}{a_2}, A_3 = 0$
isentropic flow	$a_1 = \frac{a_2 b_1}{b_2}, c_1 = \frac{b_1 c_2}{b_2}$	solution does not exist	solution does not exist

Several comments on the solutions of Euler- and Navier-Stokes equations (1).

1. It is clear that all real harmonic functions are the solutions of Euler- and Navier-Stokes equations (1), [4]. From the viewpoint of the method presented in this paper, it is the special case of this method. Further, the parameters $a_k, b_k, c_k, k = 1, 2$ collected in the Table 1, cause the solution is complex. However, although this fact and the non-existence of the solutions of second kind and combined

solutions for Euler- and Navier-Stokes equations, we can try to apply the point 4 of some important remarks from the previous section. Hence, we can show that there in this case exists more general (and real) solution, than the original solution of first kind, (some suggestion is included in [4]):

$$u(x, y, t) = \beta_1 + f(x^0, a_k x^k + \beta_2, b_k x^k + \beta_3, c_k x^k + \beta_4) + \\ + f(x^0, a_k^* x^k + \beta_2^*, b_k^* x^k + \beta_3^*, c_k^* x^k + \beta_4^*) \quad (11)$$

where $a_k, b_k, c_k, k = 1, 2$ are given in Table 1 and “*” denotes complex conjugation.

2. Besides there exists semi-second kind solution:

$$u(x, y, t) = \beta_1 + h_1(x^0)x^1 + h_2(x^0)x^2 + \\ + h_3(x^0)x^1x^2 + h_4(x^0) \cdot ((x^1)^2 - (x^2)^2) \quad (12)$$

where $h_j(x^0) \in R, j = 1, 2, 3, 4$ are *arbitrary* functions of class C^2 . This is such, because there in Laplace equation is no differentiation with respect to the variable x^0 and thanks to this fact we can put here arbitrary functions of this variable.

3. The most general solution, which we can give here for Euler- and Navier-Stokes equations (1), from the viewpoint of the ansatz of second kind and combined ansatz, has the form:

$$u(x, y, t) = \beta_1 + h_1(x^0)x^1 + h_2(x^0)x^2 + h_3(x^0)x^1x^2 + \\ + h_4(x^0) \cdot ((x^1)^2 - (x^2)^2) + f(x^0, a_k x^k + \beta_2, b_k x^k + \beta_3, c_k x^k + \beta_4) + \\ + f(x^0, a_k^* x^k + \beta_2^*, b_k^* x^k + \beta_3^*, c_k^* x^k + \beta_4^*), \quad (13)$$

where $a_k, b_k, c_k, k = 1, 2$ are given in Table 1 and $h_j(x^0) \in R, j = 1, 2, 3, 4$ are *arbitrary* functions of class C^2 . As we see, in this case we have a *superposition* of (11) and (12).

4.2. Figures of the semi-combined solution of Navier-Stokes equation

Hereunder we present the figures of *a fragment* of an animation of the semi-combined solution (13), when $h_1(t) = h_2(t) = h_3(t) = 0, h_4(t) = \exp(-t^2), a_1 = 2, b_1 = 4, c_1 = 5, \beta_i = 0, i = 1, 2, 3, 4, x \in (-5, 5), y \in (-10, 10), t \in (10, 1000)$ and the number of plot points was equal to 50.

$$u(x, y) = \exp(-t^2) * (x^2 - y^2) + \\ + \exp(\coth(\tan(t) + (2x + 2iy) + (4x + 4iy)(5x + 5iy))) + \\ + \exp(\coth(\tan(t) + (2x - 2iy) + (4x - 4iy)(5x - 5iy))) \quad (14)$$

Because of limited space of this paper, we present only four figures of the animation.

In the order to do this animation we used the package “Graphics ‘Animation’” and the function “MoviePlot3D” of MATHEMATICA.

Three first figures (Figs 1 and 2) present an evolution of the mentioned solution within the interval $t \in (10, 1000)$ and on the four figure we see the solution at the end of the interval, when $t = 1000$.

In [3] so called 2δ pulse solution of double sinus-Gordon equation was presented. The first three figures show something, which is very similar to a colision of such two 2δ pulse solutions, however, of course it is to be investigated later, [8]. If we look at the Figure 3, which present the solutions at the end of time interval, we can say that the presented solutions seem to not decay in time, but obviously, a question about their stability is open [8].

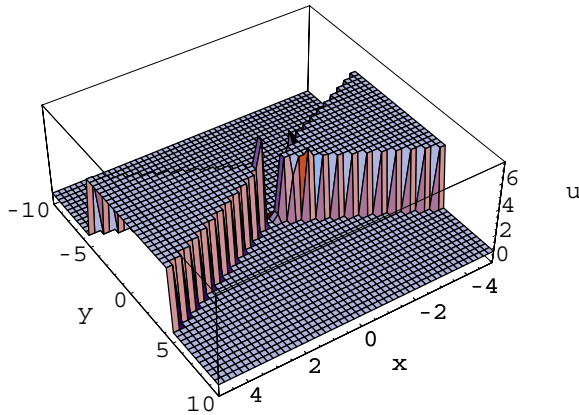

Fig. 1. Solution (14)

5. Conclusions and future work

As far as the solution of first kind of Monge-Ampere equation (2) is concerned: this solution has been presented in [2], but by applying the symmetry analysis method.

The presented method gives for the investigated equations enough wide classes of exact solutions and it seems to be easier for applications, than for example symmetry analysis method. Moreover, if we look on the ansatzes (6)–(8) may be generalized to the ansatzes dependent on more arguments, like these ones, occuring in (6)–(8).

From the other hand, this method requires some carefulness, when there is required that the solution has to be real function, because often the roots of the system of algebraic equations turn to be complex numbers and sometimes it is easy to obtain unphysical solutions. This paper is concerned only several examples of application of the decomposition method. Future work will be related to a generalization of the ansatzes, extension of this method for other families of NPDE's and to investigation of the physical features of obtained solutions, [8].

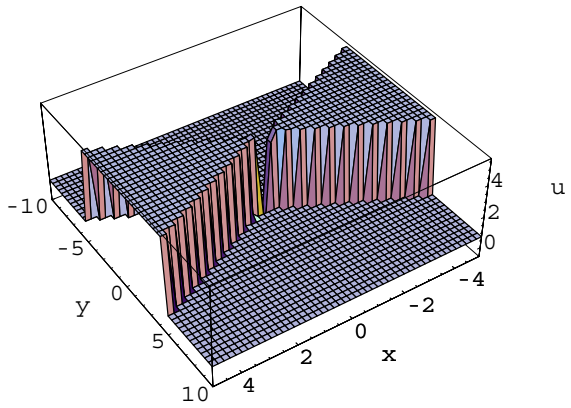
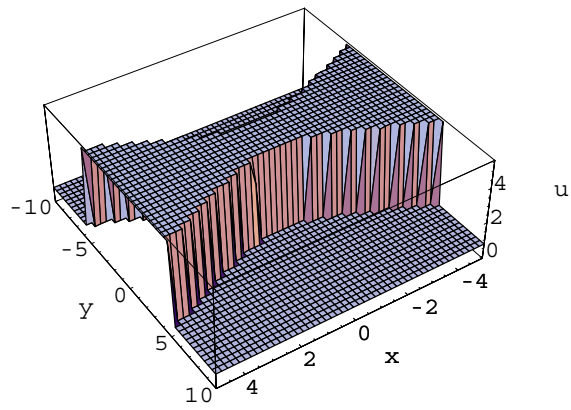

Fig. 2. Solution (14)

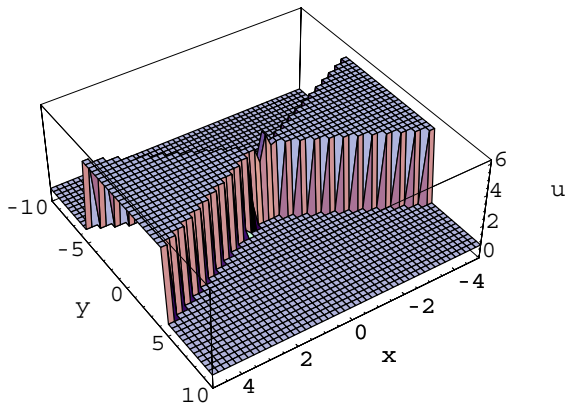

Fig. 3. Solution (14) in $t = 1000$

Acknowledgements

The author appreciates to Department of Computer Sciences and Computer Methods of Pedagogical University in Krakow for the support of his participation in the The Conference of the High Performance Computers' Users (KU KDM ACK-CYFRONET AGH), (March 7–8th 2008) in Zakopane.

References

- [1] Bai C. L., Zhao H., Han J. G.: *Czech. J. Phys.*, **56**, 237 (2006)
- [2] Fushchich W. I., Shtelen W. M., Serov N. I., *Symmetry analysis and exact solutions of equations of nonlinear mathematical physics*, Kluwer Academic Publishers, 1989
- [3] J. Gibbon: *The Interaction of Spin Waves in Liquid He³ in Several Dimensions*. [in:] *Solitons and Condensed Matter Physics*, Editors: A. R. Bishop, T. Schneider, Springer-Verlag 1978
- [4] Polyanin A. D., Zaitsev V. F.: *Handbook of nonlinear partial differential equations* Chapman & Hall/CRC 2004, p. 616
- [5] Sokalski K., Stępień Ł. T., Sokalska D.: *J. Phys. A: Math. Gen.*, **35**, (1) 6157 (2002)
- [6] Sokalski K., Wietecha T., Sokalska D.: *J. Nonl. Math. Phys.*, **12**, 31 (2005)
- [7] Ł. T. Stępień: *Some decomposition method for analytic solving of certain nonlinear partial differential equations in physics with applications. A talk delivered during the conference. Special Functions, Information Theory and Mathematical Physics An interdisciplinary conference in honor of Prof. Jesús S. Dehesa's 60th birthday* Sept 17–19th 2007, Granada, Spain (an extended version of this talk is to be appeared in a special issue of J. Comp. Appl. Math.)
- [8] Ł. T. Stępień, work in progress